

Table of Content (目录)

1. ELECTRICAL SPECIFICATION/电气特性	5
1.1 GENERAL SCOPE/概述.....	5
1.2 PRODUCT DESCRIPTION/产品描述.....	5
2. INPUT CHARACTERISTICS/输入特性	5
2.1 INPUT VOLTAGE AND FREQUENCY/输入电压与频率.....	5
2.2 INPUT AC CURRENT/输入交流电流.....	5
2.3 INRUSH CURRENT/浪涌电流.....	5
2.4 INPUT FUSE/输入保险丝.....	5
2.5 AVERAGE EFFICIENCY/平均效率.....	5
2.6 NO LOAD POWER CONSUMPTION/空载功耗.....	5
3. OUTPUT CHARACTERISTICS/输出特性	6
3.1 OUTPUT VOLTAGE REGULATION/输出电压调整率.....	6
3.2 RIPPLE AND NOISE/纹波&噪声.....	6
3.3 TURN ON DELAY TIME/开机延迟时间.....	7
3.4 RISE TIME/上升时间.....	7
3.5 HOLD UP TIME/保持时间.....	7
3.6 OUTPUT OVERSHOOT/输出过冲.....	7
3.7 DYNAMIC LOAD/动态负载.....	7
4. PROTECTION REQUIREMENTS/保护功能	7
4.1 SHORT CIRCUIT PROTECTION/短路保护.....	7
4.2 OVER CURRENT PROTECTION/过流保护.....	7
4.3 OVER VOLTAGE PROTECTION/过压保护.....	8
5. ENVIRONMENTAL REQUIREMENTS/环境要求	8
5.1 TEMPERATURE/温度.....	8
5.2 HUMIDITY/湿度.....	8
5.3 OPERATING ALTITUDE/海拔高度.....	8
5.4 COOLING/冷却方式.....	8
5.5 WEATHER CONDITIONS/气候条件.....	8
6. RELIABILITY REQUIREMENTS/可靠性要求	8
6.1 MTBF QUALIFICATION/平均间隔故障时间估算.....	8
6.2 E-CAP LIFETIME/电解电容寿命.....	8
6.3 LOW TEMPERATURE STORAGE TEST/低温贮存试验.....	8
6.4 LOW TEMPERATURE OPERATING TEST/低温运行试验.....	9

6.5 HIGH TEMPERATURE STORAGE TEST/高温贮存试验	9
6.6 HIGH TEMPERATURE OPERATION TEST/高温运行试验	9
6.7 TEMPERATURE IMPACT TEST/温度冲击试验	9
6.8 CONSTANT DAMP HEAT TEST/恒定湿热试验	9
6.9 SALT SPRAY TEST/盐雾试验	10
6.10 NOISE TESTING/噪音测试	10
6.11 DROP OF MONOMER/单体跌落	10
6.12 VIBRATION TEST/振动测试	10
6.13 WIRE SWING TEST/线材摇摆测试	11
6.14 TEST OF TENSILE STRENGTH OF WIRE/线材抗拉力测试	11
6.15 AC PIN ANGLE LIFE TEST/交流输入插脚寿命测试	11
6.16 BURN-IN TEST/老化测试	11
6.17 AC ON/OFF TESTING/输入开关机测试	11
6.18 BALL PRESSURE TEST/球压测试	11
7. SAFETY AND EMI REQUIREMENTS/安全及 EMI 要求	12
7.1 HI-POT TEST/高压测试	12
7.2 INSULATION RESISTANCE/绝缘阻抗	12
7.3 SAFETY STANDARDS/安规标准	12
7.4 EMI/电磁干扰	13
7.5 EMS/电磁抗扰度	14
8. MECHANICAL REQUIREMENTS/结构参数	14
8.1 ENCLOSURE/外壳	14
8.2 INPUT CONNECTOR/输入插脚	14
8.3 OUT CONNECTOR/输出线材及插头	15
8.4 OUTLINE DIMENSIONS/机构图(UNIT: MM)	16
8.5 LABEL/铭牌	17
8.6 PACKAGE/包装	18
8.7 CIRCUIT DRAWING/原理图	19
8.8 PCB DRAWING/PCB 绘图	20
8.9 BILL OF MATERIALS/材料清单	21

1. Electrical Specification/电气特性

1.1 General Scope/概述

The specification defines the performance characteristics of a 65 W Switching Power adapter. All products including samples delivered will meet all the requirements as outlined in the document.

The basic requirements of the design features are listed below:

这是一份详细描述总功率为 65 瓦的开关电源适配器的规格承认书。所有提供的产品包括样品将满足本文文件所描述的产品规格。其设计基本要求如下:

1.2 Product Description/产品描述

- SMPS Adaptor(Wall mount)插墙式适配器 SMPS Adaptor(Desk-top)桌面型适配器
 SMPS Unit(With Case)带铁壳型电源 Li-ion battery charger 锂电池充电器
 Others 其他型电源

2. Input Characteristics/输入特性

2.1 Input Voltage And Frequency/输入电压与频率

Rated input voltage 额定输入电压	200Vac to 240Vac
Limited working Range 极限工作范围	180Vac to 264 Vac
Frequency range 频率范围	50Hz/60Hz±5%

2.2 Input AC Current/输入交流电流

1.0Arms Max at 200 Vac input and full load.在 200Vac 输入和满载条件下最大 1.0A.

2.3 Inrush Current/浪涌电流

No damage at cold or hot start.冷热机条件下开机不可出现损坏。

2.4 Input Fuse/输入保险丝

Input voltage 264Vac to 0Vac,The input fuse shall not blow up at full load.输出满载条件下，输入电压从 264Vac 降至 0Vac 时输入保险丝不可爆裂。

2.5 Average Efficiency/平均效率

输出条件	最低平均效率
5V/3A	75%
9V/3A	80%
12V/3A	80%
15V/3A	85%
20V/3.25A	85%

2.6 No Load Power Consumption/空载功耗

Input voltage 230Vac and the output is no load conditions,the input power loss must be less than 0.21W.

输入电压 230Vac,输入空载功率小于 0.21W.

3. Output Characteristics/输出特性

3.1 Output voltage regulation/输出电压调整率

Output Voltage 输出电压	Load(A)负载		Regulation(V)调整率	
	Min 最小负载	Max 最大负载	Load regulation 负载调整率	Line regulation 线性调 整率
5V	0	3	±10%	±2%
9V	0	3	±10%	±2%
12V	0	3	±10%	±2%
15V	0	3	±10%	±2%
20V	0	3.25	±10%	±2%

1.Line regulation is measured from 180Vac to 264Vac 线性调整率的测试条件是 180Vac 到 264Vac

2.Load regulation is measured all output from min load to max load at 200Vac to 240Vac input voltage

负载调整率的测试条件是在 200Vac to 240Vac 输入情况下，最小载到最大载之间变化。

3.2 Ripple and noise/纹波&噪声

Output Voltage 输出电压	Ripple/Noise(peak-peak)(mV)
5V/9V/12V/15V/20V	≤200

1.The ripple is measured from peak to peak with bandwidth limit of 20MHz.纹波是使用示波器带宽为 20MHz 测量峰峰值得到的。

2.Input voltage at 180~264Vac and full load, a 0.1uF ceramic disk capacitor & 10uF electrolytic(low ESR) capacitor should be put across the output terminals during ripple & noise measure as fig below.

在输入 180~264Vac,输出满载的情况下,测试纹波和噪声需要在输出端并联一个 0.1uF 的瓷片电容和一个 10uF 低内阻的电解电容,如下图。

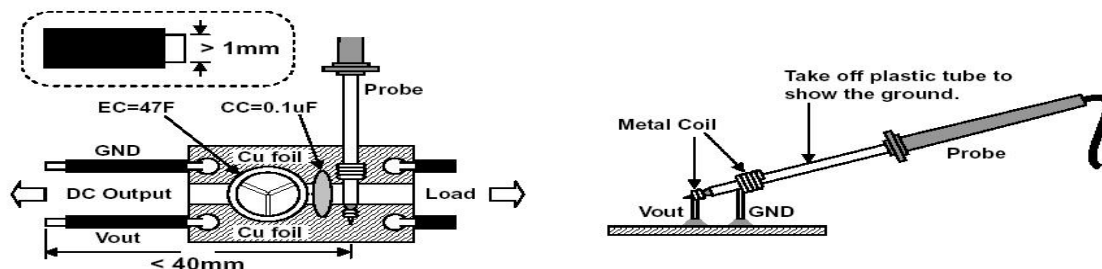

3.3 Turn on delay time/开机延迟时间

The turn on delay time is 3 seconds Max. At 200Vac input and output full load.

当输入 200Vac,输出满载时,开机延迟时间最大为 3 S.

3.4 Rise time/上升时间

The output rise time is 50mS Max, at 200Vac input and output is Max load.

当输入 200Vac,输出最大负载时最大上升时间 50mS.

3.5 Hold up time/保持时间

10mS Min. at 200Vac input and output Max. load.

当输入 200Vac,输出最大负载时最小保持时间为 10mS.

3.6 Output Overshoot/输出过冲

Under the condition of input voltage 200~240Vac, the output impulse voltage is less than $\pm 10\%$.

在输入电压 200~240Vac, 额定负载输出条件下,开机或关机时输出过冲电压小于额定电压的 $\pm 10\%$.

3.7 Dynamic Load/动态负载

The output voltage will remain within the regulation after applying following load changes . The measurement shall be done at DC connector.

在以下负载条件变化情况下,输出端子两端电压测试,输出电压应在表格范围内。

Voltage tolerance limit	Duty	Slew Rate	Load Change	Transient frequency
4.2-6.0V	50%	0.2A/US	20% ~ 80%	1KHz
8.1-9.9V	50%	0.2A/US	20% ~ 80%	1KHz
10.8-13.2V	50%	0.2A/US	20% ~ 80%	1KHz
13.5-16.5V	50%	0.2A/US	20% ~ 80%	1KHz
18-22V	50%	0.2A/US	20% ~ 80%	1KHz

4. Protection requirements/保护功能

4.1 Short circuit protection/短路保护

Power adapter shall have self-limiting protection to protect against short circuit or overload conditions.

No damage to the power adapter shall result from a continuous or intermittent short circuit condition. It will be auto-recovered when the failure is removed.

电源适配器有自我限制保护功能来防止短路或过载条件,在连续或断续的短路条件下电源将不会有任何损坏。短路故障排除后,电源将会自动恢复正常工作。

4.2 Over current protection/过流保护

The maximum OCP current is 5.0A ,After output current of power supply reach OCP current,the

over current protection shall operate, the power supply will be

auto- recovered when over current faults remove.电源最大输出过流保护点为 5.0A。发生过流后,保护将会动作,过流故障排除后,电源将自动恢复正常工作。

4.3 Over Voltage protection/过压保护

The maximum OVP voltage is 28V, After output Voltage of power supply reach OVP voltage.The over Voltage protection shall operate, the power supply will be auto- recovered when over Voltage faults remove.

电源最大输出电压保护点为 28V。发生过压后,保护将会动作。过压故障排除后,电源将自动恢复正常工作。

5. Environmental requirements/环境要求

5.1 Temperature/温度

Operating temperature:-10°C to +40°C.正常工作温度为-10°C至+40°C。

Storage temperature:-20°C to +70°C.存储温度为-20°C至+70°C。

5.2 Humidity/湿度

Operating humidity:5% to 95%(non-condensing).正常工作湿度为 5%至 95%(无冰凝结条件下)。

Storage humidity:5% to 95%(non-condensing).存储湿度为 5%至 95%(无冰凝结条件下)。

5.3 Operating Altitude/海拔高度

≤5000m Elevation.最大海拔高度小于或等于 5000 米。

5.4 Cooling/冷却方式

Cooling shall be with natural convection cooling.空气自然对流冷却。

5.5 Weather conditions/气候条件

Conform to the tropical climate.适用于热带地区

6. Reliability requirements/可靠性要求

6.1 MTBF qualification/平均间隔故障时间估算

The MTBF shall be at least 50000hours at 25°C,full load and input voltage 230Vac conditions, calculated using the Telcordia SR-332 issue2.平均间隔故障时间至少 50000 小时,在 25°C环境及满载输出,输入电压为 230Vac 条件下,计算使用标准 Telcordia SR-332。

6.2 E-cap Lifetime/电解电容寿命

The life estimation of aluminum capacitor shall be at least 10000 hours at 25°C, of full load and input voltage 230Vac conditions.铝电解电容寿命计算至少 10000 小时,在 25°C环境及满载输出,输入电压为 230Vac 条件下。

6.3 Low temperature storage test/低温贮存试验

Shutdown state,(-40°C±3°C) low temperature storage 48 h, normal temperature recovery 2 h after inspection. After testing, the basic functions, appearance and assembly inspection should

be able to meet the corresponding requirements 关机状态, $(-40^{\circ}\text{C}\pm 3^{\circ}\text{C})$ 低温存储 48h, 常温恢复 2h 后检查.测试后进行基本功能、外观及装配检测, 应能符合相应的要求.

6.4 Low temperature operating test/低温运行试验

The charger is electrified and full load, $(-10^{\circ}\text{C}\pm 3^{\circ}\text{C})$ low temperature test 16h; normal temperature recovery 2 h after inspection. The basic function, appearance and assembly inspection should meet the requirements after normal temperature recovery.

将充电器通电满载工作, $(-10^{\circ}\text{C}\pm 3^{\circ}\text{C})$ 低温试验 16h; 常温恢复 2h 后检查.常温恢复后基本功能、外观及装配检测应符合要求。

6.5 High temperature storage test/高温贮存试验

Shutdown state, $(85^{\circ}\text{C}\pm 3^{\circ}\text{C})$ high temperature storage 48 h, normal temperature recovery 2 h after inspection. After testing, the basic function, appearance and assembly inspection should be able to meet the corresponding requirements.

关机状态, $(85^{\circ}\text{C}\pm 3^{\circ}\text{C})$ 高温存储 48h, 常温恢复 2h 后检查.测试后进行基本功能、外观及装配检测, 应能符合相应的要求。

6.6 High temperature operation test/高温运行试验

The charger is electrified and full load, $(45^{\circ}\text{C}\pm 3^{\circ}\text{C})$ high temperature test 16h; normal temperature recovery 2 h after inspection. The basic function, appearance and assembly inspection should meet the corresponding requirements after normal temperature recovery.

将充电器通电满载工作, $(45^{\circ}\text{C}\pm 3^{\circ}\text{C})$ 高温试验 16h; 常温恢复 2h 后检查.常温恢复后基本功能、外观及装配检测应能符合相应的要求。

6.7 Temperature Impact Test/温度冲击试验

Shutdown state, $(-40^{\circ}\text{C}\pm 3^{\circ}\text{C})/(65^{\circ}\text{C}\pm 3^{\circ}\text{C})$ 30 minutes each temperature impact 16 cycles, starting from low temperature, high and low temperature switching time requirements less than 3 min, normal temperature recovery 2 h after the inspection function, appearance and assembly inspection should meet the requirements.

关机状态, $(-40^{\circ}\text{C}\pm 3^{\circ}\text{C}) / (+65^{\circ}\text{C}\pm 3^{\circ}\text{C})$ 各 30 分钟的温度冲击 16 个循环, 由低温开始, 高低温切换时间要求小于 3min, 常温恢复 2h 后检查功能、外观及装配检测应符合要求。

6.8 Constant damp heat test/恒定湿热试验

Water for humidification: distilled or deionized water with PH values between 6.0~7.2 at 23°C. Water.

加湿用水: 蒸馏水或去离子水, 该水在 23°C 时, PH 值 6.0~7.2 之间.

Power charger full load $(50^{\circ}\text{C}\pm 2^{\circ}\text{C})$, relative humidity $93\%\pm 3\%$, 48 hours.

将充电器通电满载工作 $(50^{\circ}\text{C}\pm 2^{\circ}\text{C})$, 相对湿度 $93\%\pm 3\%$, 48 小时.

The temperature and humidity of the test box shall be restored to standard atmospheric

conditions for testing and testing within 1 h~4 h after the test,

Once the cooling stage is over, the DUT should enter the recovery procedure, and the inspection function, appearance and assembly inspection should be normal after 2 h of recovery.

试验结束后,应在1h~4h内将试验箱的温度和湿度恢复到检测和试验用的标准大气条件,降温阶段一结束,DUT就应进入恢复程序,恢复2h后检查功能、外观及装配检测应正常.

6.9 Salt spray test/盐雾试验

Two spray cycles ,2 hours each, followed by a 22 hour period of damp-heat storage, with a temperature (15-35)°C and a concentration of (5±1)% sodium chloride solution; storage conditions (40±2°C), with a relative humidity of 90%~95%; after the experiment was completed, the appearance, function and mechanical structure of the DUT were tested after 24 h in normal, normal and atmospheric environment. (Note: if the DUT need to be cleaned, the temperature < 35°C distilled water or deionized water after cleaning and drying)

2个喷雾周期,每个2小时,每个喷雾周期后有一个为期22小时的湿热存储周期,喷雾条件为温度(15-35)°C,浓度为(5±1)%的氯化钠溶液;储存条件为(40±2°C),相对湿度达到90%~95%;实验完成后在常温、常湿、常压环境中放置24h后对DUT进行外观、功能及机械结构检测,应正常,金属部分不能腐蚀.

(注:如需清洗的DUT需用温度<35°C蒸馏水或者去离子水清洗干燥后检测)

6.10 Noise testing/噪音测试

When rated load and no load,noise from the adapter should be heard less than 26dB.30 cm from the adapter(Environment :<20 dBA)

额定负载和空载时,在离适配器30cm的地方,听到来自适配器的噪音应低于26dB.

(环境: <20dBA)

6.11 Drop of monomer/单体跌落

Height 1 m,free to fall on the cement floor,six sides (in the order of minimum /middle/maximum order drop)for a round of 2 rounds, a total of 12 times. The components should not be loosened after falling, and the shape of the shell should not change.

高度1米,自由跌落在水泥地板上,六面(按最小面/中面/最大面顺序跌落)为一轮;2轮,共12次.跌落后元器件不应该松动,外壳形状不应发生变化.

6.12 Vibration test/振动测试

Test 7~50 HZ adopt fixed amplitude 0.8 mm,50~200 HZ fixed acceleration 4g.

X,Y,Z axis 1 hour.

测试7~50HZ采用定幅0.8mm,50~200HZ定加速度4g,X,Y,Z轴各1小时.

DUT internal should be silent or obvious parts loose, all functions,performance normal. DUT内部应无声响或明显部件松动,各项功能、性能正常.

6.13 Wire Swing Test/线材摇摆测试

Cable swing test condition, lifting weight 300 g, swing Angle ± 60 degrees, swing frequency 30 times / minute, reciprocation, SR swing 2000 times, DC head swing 2000 times, test wire appearance is not broken, and normal charging function. 线材摇摆测试条件, 吊重 300 克, 摇摆角度 ± 60 度, 摇摆频率 30 次/分钟, 往复算一次, SR 摇摆 2000 次, DC 头摇摆 2000 次, 试验后线材外观无破损断裂, 充电功能正常.

6.14 Test of tensile strength of wire/线材抗拉力测试

The end of the wire is suspended from top to bottom with a weight of 3 kg for 1 min. After the wire appearance is not damaged and broken, the charging function is normal. 将线数据线线材末端处自上而下悬挂一个重量为 3kg 的砝码持续 1min 后线材外观无破损断裂, 充电功能正常.

6.15 AC pin angle life test/交流输入插脚寿命测试

The insertion and pull-out is 1 time, and the corresponding AC pin is inserted and pulled 2000 times at the rate of 20-30 times per minute. The AC pin pull-out force is less than 40 N, more than 8. After the test, the mechanical structure should not be damaged, good contact can be charged and used normally. Photo confirmation of AC pin foot. 插入与拔出为 1 次, 以每分钟插拔 20-30 次的速率与这对应 AC pin 垂直插拔 2000 次插拔; AC pin 拔出力小于 40N, 大于 8N; 试验后机械结构应无损坏, 接触良好能正常充电及正常使用, 要求对 AC pin 脚拍照确认.

6.16 Burn-In test/老化测试

Burn-In temperature 40°C, 220ac input, rated load 80-100% continuous work 168h. The electrical performance of the test sample should be normal after the test. 老化温度 40°C, 220ac 输入, 额定负载 80%-100% 持续工作 168h, 试验样品在试验后电气性能需正常.

6.17 AC on/off testing/输入开关机测试

The AC on/off is input voltage 220Vac, output full load, 5 S on / 5 S off once, test 3000 times. 220Vac 输入, 输出满载, 5S 开/5S 关为 1 次, 测试 3000 次.

Power supply should not be damaged after testing. 测试完后电源不能损坏.

6.18 Ball pressure test/球压测试

Pretreatment, test sample temperature between 15°C~35°C, relative humidity between 45~75 placed at least 24 h.

预测前, 将试验样品温度在 15°C ~ 35°C 之间, 相对湿度在 45 ~ 75 之间至少放置 24h.

Place the sample in an oven of 125°C, the surface of which should be horizontal, press the spherical part of the 20 N device to the surface, place it in cold water for 1 hour, cool it to room temperature within 10 s, then measure the diameter of the ball mark not more than 2 mm.

将试样放入在 125°C 的烤箱内, 其表面需水平, 用 20N 装置的球状部分压到此表面, 放置 1 小时后取出浸入冷水中, 使其在 10s 内冷却到室温, 然后测量球痕直径不超过 2mm.

7. Safety and EMI requirements/安全及 EMI 要求

7.1 Hi-pot test/高压测试

Hi-pot test shall meet with the following table test requirements, 100% production test must be performed for each test item and be maintained at that level for a minimum of 5seconds without failure.

高压测试满足下表的要求,100%在线间品执行此项测试,并每一项目至少保持 1min 时间无任何故障。

ITEM	SPECIFICATION	REMARK
Primary to Secondary 输入 - 输出	3000Vac 或 4000Vdc/10mA/1min	No arcing No broken/无飞狐无击穿
Primary to P.G/输入 - 地	---	---
Note:Factory test criteria for mass production shall be 3.6KVac ,3S,5mA		

7.2 Insulation resistance/绝缘阻抗

ITEM	SPECIFICATION	REMARK
Primary to Secondary 输入 - 输出	> 100MΩ;DC500V	---
Primary to P.G/输入 - 地	---	---

7.3 Safety standards/安规标准

safety:accord with(安全:符合标准)

Certificate	Country/国家	Standards/标准
<input type="checkbox"/> CCC	China/中国	GB8898-2011
<input type="checkbox"/> CCC	China/中国	GB4943-2011
<input type="checkbox"/> CCC	China/中国	GB4943.1-2022
<input type="checkbox"/> CQC	China/中国	GB4706
<input type="checkbox"/> CQC	China/中国	GB9706
<input type="checkbox"/> UL/CUL	USA/美国	UL62368
<input type="checkbox"/> UL/CUL	USA/美国	UL1310
<input type="checkbox"/> UL/CUL	USA/美国	UL60601-1
<input type="checkbox"/> CB	/	IEC62368
<input type="checkbox"/> CB	/	IEC60335
<input type="checkbox"/> CB	/	IEC61558
<input type="checkbox"/> CB	/	IEC60601-1
<input type="checkbox"/> GS	Europe/欧洲	EN62368

<input type="checkbox"/> GS	Europe/欧洲	EN 60335
<input type="checkbox"/> GS	Europe/欧洲	EN 61558
<input type="checkbox"/> GS	Europe/欧洲	EN 60601-1
<input type="checkbox"/> CE	Europe/欧洲	EN62368
<input type="checkbox"/> CE	Europe/欧洲	EN 60335
<input type="checkbox"/> CE	Europe/欧洲	EN 61558
<input type="checkbox"/> CE	Europe/欧洲	EN 60601-1
<input type="checkbox"/> UKCA	England/英国	BS EN62368
<input type="checkbox"/> UKCA	England/英国	BS EN 60335
<input type="checkbox"/> UKCA	England/英国	BS EN 61558
<input type="checkbox"/> UKCA	England/英国	BS EN 60601-1
<input type="checkbox"/> RCM	Australia/澳洲	AS/NZS 62368
<input type="checkbox"/> RCM	Australia/澳洲	AS/NZS 60335
<input type="checkbox"/> RCM	Australia/澳洲	AS/NZS 61558
<input type="checkbox"/> RCM	Australia/澳洲	AS/NZS 60601-1
<input type="checkbox"/> PSE	Japan/日本	J62368
<input type="checkbox"/> PSE	Japan/日本	J60335
<input type="checkbox"/> PSE	Japan/日本	J61558
<input type="checkbox"/> PSE	Japan/日本	J60601-1
<input type="checkbox"/> KC	Korea/韩国	K62368
<input type="checkbox"/> KC	Korea/韩国	K60335
<input type="checkbox"/> KC	Korea/韩国	K61558
<input type="checkbox"/> KC	Korea/韩国	K60601-1
<input type="checkbox"/> EAC	Russia/俄罗斯	EN 62368
<input type="checkbox"/> EAC	Russia/俄罗斯	EN 60335
<input type="checkbox"/> EAC	Russia/俄罗斯	EN 61558
<input type="checkbox"/> EAC	Russia/俄罗斯	EN 60601-1

7.4 EMI/电磁干扰

EMI:accord with(EMI: 符合标准)

<input type="checkbox"/> EN55032	Electromagnetic compatibility of multimedia equipment —Emission requirements 多媒体设备的电磁兼容性.发射要求
<input type="checkbox"/> J55032	
<input type="checkbox"/> K32	
<input type="checkbox"/> GB9254.1-2022	Information technology equipment, multimedia equipment and receivers—Electromagnetic compatibility—Part 1: Emission

	requirements 信息技术设备、多媒体设备和接收机电磁兼容第 1 部分:发射要求
<input type="checkbox"/> GB4343.1 <input type="checkbox"/> EN55014-1 <input type="checkbox"/> J55014-1 <input type="checkbox"/> K55014-1	Electromagnetic compatibility Requirements for household appliances, electric tools and similar apparatus Part 1:Emission 电磁兼容 家用电器, 电动工具和类似器具的要求 第 1 部分: 发射
<input type="checkbox"/> FCC Part 15 B	FCC CFR 47 Part 15 subpart B 美国联邦通信法规第 47 卷 15 章内无意式的辐射器材的相关规定
<input type="checkbox"/> ICES-003:Issue 7	Electromagnetic compatibility of Information Technology Equipment (including Digital Apparatus) Emission requirements for Canada 加拿大信息技术设备(包含数字设备) 电磁兼容.发射要求

7.5 EMS/电磁抗扰度

EMS:accord with/EMS: 符合标准

<input type="checkbox"/> EN55035 <input type="checkbox"/> K35	Information technology equipment ,Sound and television broadcast receivers—Immunity characteristic limits and methods of measurement 信息技术设备、声音和电视广播接收机抗扰度测量限值和方法	
EN61000-4-2 GB/T17626.2	Electrostatic discharge immunity test 静电放电抗扰度测试	CON:±6KV; AIR:±8KV; 10 charge/point for Con; 10 charge/point for Air Meet criteria: B
EN61000-4-4 GB/T17626.4	Electrical fast transient/burst immunity test 电快速瞬变脉冲群抗扰度测试	AC port:±1KV Meet criteria: B
EN61000-4-5 GB/T17626.5	Surge immunity test 浪涌抗扰度测试	AC port: L-N:±1KV L-PE/N-PE:±2KV 1.2/50uS-8/20uS phase position: 0, 90, 180, 270 Meet criteria: B

8. Mechanical requirements/结构参数

8.1 Enclosure/外壳

The power supply size/外壳尺寸:66*66*30mm

Black appearance/外观为黑色

8.2 Input connector/输入插脚

3C two pin input plug/2pin 大陆插脚

AC Pin foot push tension test: apply the 20kg thrust or tension at the AC Pin foot and hold it for

1 minute. After the experiment, the AC Pin foot did not fall off.

AC Pin 脚推拉力试验: 在 AC Pin 脚处施加 20kg 的推力或者拉力, 保持 1 分钟, 实验后 AC Pin 脚无脱落.

8.3 Out connector/输出线材及插头

DC cord/输出线:UL2464 直头

Length/总长:1500mm

DC plug/DC 头尺寸:6.65*8.25*2.4mm.

DC head insert end insert force specification range: 3000 times, insert force 0.3-3kg/f.

DC 头插端插拔力规格范围: 3000 次, 插拔力 0.3-3kg/f.

8.4 Outline dimensions/机构图(unit: mm)

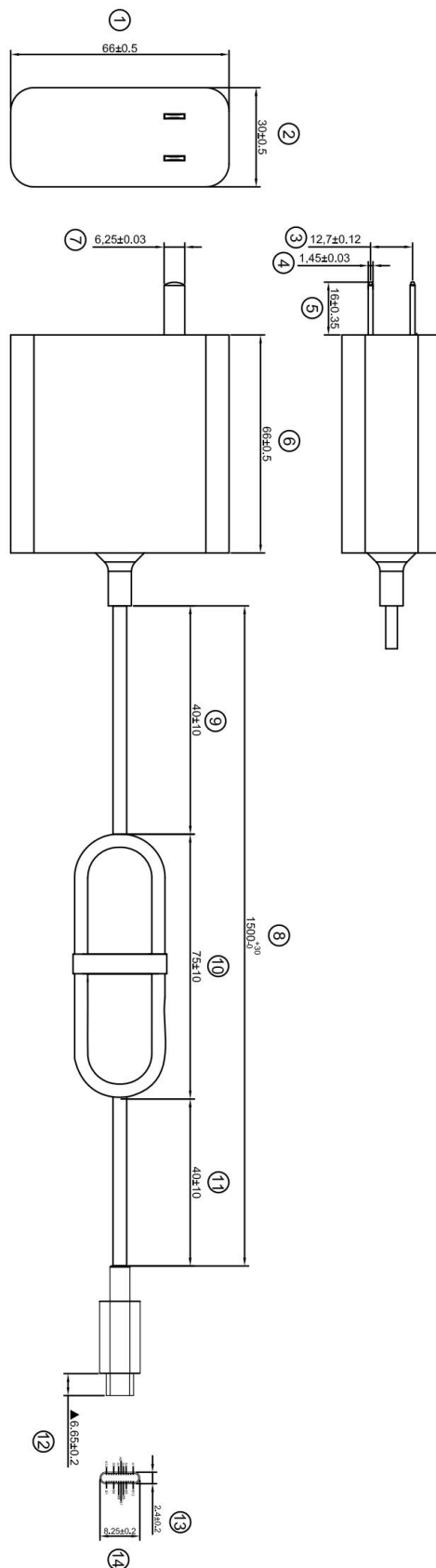

8.5 Label/铭牌



左右居中

字体：方正兰亭黑简体

8.6 Package/包装

This package is for reference only/此包装图仅供参考，最终包装方式以客户要求或公司内部确认后为准。

包装方式一：使用吸塑式包材，每箱装 75 台。

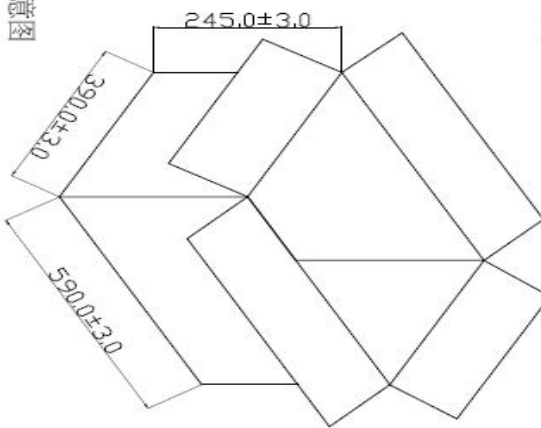
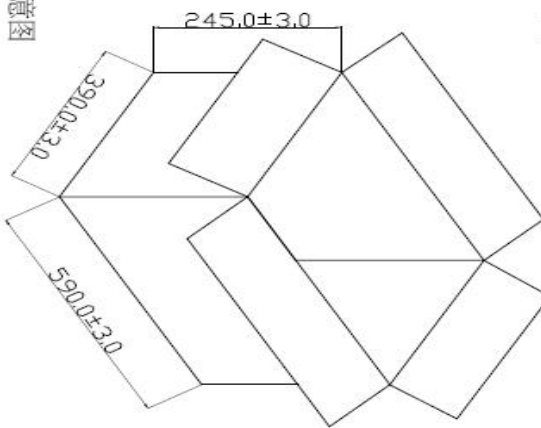
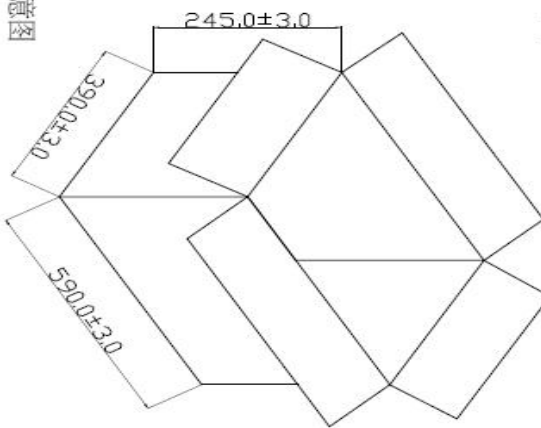
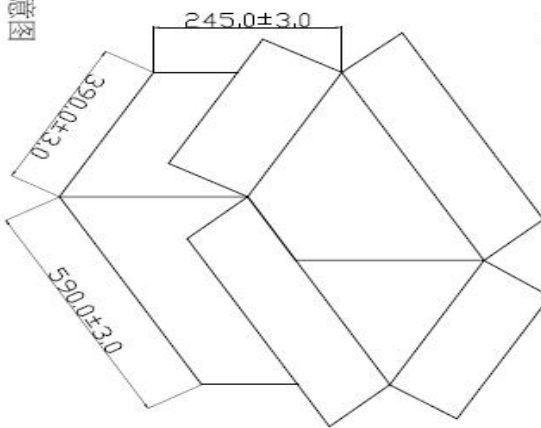
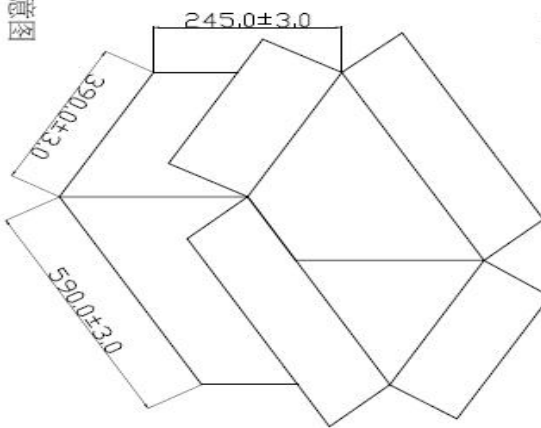
东莞市奥源电子科技有限公司 Dongguan AOYUAN Electronics Technology Co. Ltd		 <p style="text-align: center;">装箱示意图</p>		
MODEL NAME	AY12FA-AH1201002-CH	 <p style="text-align: center;">装箱示意图</p>		
DRAWING NAME	PACKING			
DWG PATH:		 <p style="text-align: center;">装箱示意图</p>		
VIEW	UNIT	 <p style="text-align: center;">装箱示意图</p>		
TOLERANCES	mm			
NO. NAME	PART NAME	SPEC	QTY/PCS	NOTE
1 纸箱	6PB00953-3100	A=A	1	每箱装175PCS
2 平卡	6PB01103-3100	A3A	2	
3 吸塑	6PB01140-5700	APET	7	
APPROVAL 1	ENGINEER	 <p style="text-align: center;">装箱示意图</p>		
APPROVAL 2	ENGINEER			
DRAWING BY	Date:	SCALE	SHEET	1/1
注意： 包装时吸塑盒需 交错叠放		